

# PRINCE

## Cuoci facile Bake it easy



**420°C**

pizze  
**9**  
pizzas

energia  
**-30%**  
energy

Prince è un forno rotativo per pizza destinato a **rendere più facile il lavoro del pizzaiolo**. Il movimento rotatorio della pietra refrattaria rende non necessario girare la pizza per raggiungere la cottura omogenea, inoltre il forno è dotato dell'innovativo sistema **P.R.S (Pizza Recall System)** che porta la pizza di fronte al pizzaiolo.

### QUALI SONO I VANTAGGI PER IL PIZZAIOLO?

Il pizzaiolo non deve girare la pizza e ha bisogno solo di una paletta corta per poter lavorare.

Prince is a top quality rotative pizza oven meant to **make the life of the pizza baker easier**. The stone inside the oven rotates and therefore there is no need to shuffle the pizzas for reaching a homogeneous baking, furthermore the oven has the unique **P.R.S (Pizza Recall System)** that brings the pizza to you.

### WHICH ARE THE ADVANTAGES OR THE PIZZA BAKER?

The pizza baker will have no need to shuffle the pizza and needs only a short spade or shovel to work.

**ATTENZIONE: 2 anni di garanzia su tutti i modelli (esclusa la centralina elettronica)**  
**WARNING: 2 years of warranty on all models (electronic board not included)**

# Forno elettrico a platea rotante Electric oven with rotating stone bottom

### FACILE

- Sistema di richiamo pizza P.R.S (Pizza Recall System) • Rotazione continua • Pannello comandi touch screen • Sistema di ribaltamento del corpo del forno a 90° che permette il passaggio anche attraverso porte di 80 cm di larghezza

### INTELLIGENTE

- Possibilità di memorizzare fino a 9 programmi di cottura • Sistema elettronico che indica ed individua eventuali malfunzionamenti • Auto mode per programmare l'orario di accensione automatica

### PERFORMANTE

- Permette la cottura con la porta aperta • Indicatore di temperatura • Controllo potenza di cielo e platea • Guaina sigillante per alte temperature per isolare al meglio la porta del forno

### ELEGANTE E DURATURO

- Completamente in acciaio inossidabile • Arreda il locale

### EASY

- P.R.S (Pizza Recall System) • Constant rotation • Touch screen display • Easy to fit tipping system (it can be tipped 90° in order to go through a 80 cm wide door)

### SMART

- Possibility to store up to 9 baking programs • Dual control system that indicated any malfunctioning • Auto mode to set switching on time

### EXCELLENT PERFORMANCE

- It allows to bake with the door open • Temperature display • Top and bottom power display • Double bulb in each baking chamber • Sealing gasket for high temperature to insulate the door

### ELEGANT AND LONG LASTING

- Totally made of stainless steel, stand too (cannot rust) • Decorative, it furnishes the pizzeria

### COME FUNZIONA?

Il forno è dotato di un touch screen che riproduce le 8 sezioni all'interno della camera di cottura del forno, toccando una sezione si ordinerà al forno di accelerare la rotazione e portare il segmento scelto davanti alla bocca del forno.

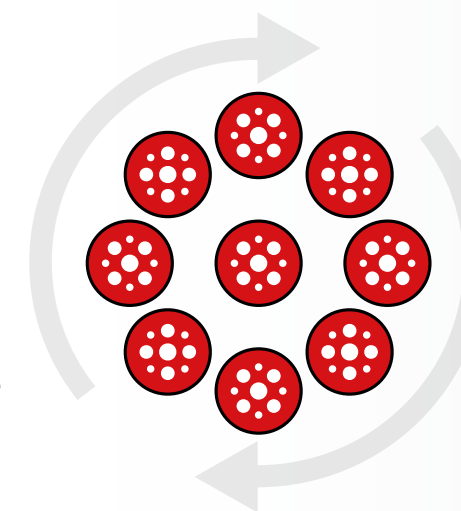

### HOW DOES THIS WORK?

The screen of the oven represents the 8 sections inside the baking chamber, by touching a section the oven will at once accelerate the rotation and the corresponding pizza will be brought directly in front of you.

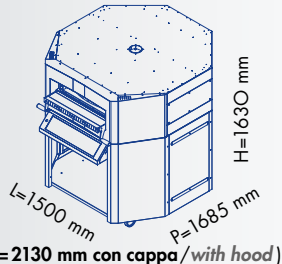
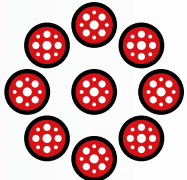

<p><b>PRINCE</b></p>  <p>(H=2130 mm con cappa/with hood)</p>	<p>n. pizze n. pizzas Ø 34 cm</p> 	<p>400 Volt AC 3/N/PE 16 kW</p> <p>Misure interne camera LxPxH Chamber internal dimensions LxDxH Ø 1300 mm</p>	<p>60 - 420 °C</p> <p>600 kg</p>	<p>Prezzo senza cappa Price without hood € 14.200,00</p>
---	---	--	----------------------------------	--

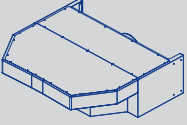
<p><b>Cappa Hood</b></p> 		<p>230 Volt AC 1/N/PE 0,11 kW</p> <p>Misure LxPxH Dimensions LxDxH 1500 x 1370 x 500 mm</p>	<p>705 mc/h</p> <p>70 kg</p>	<p>€ 2.049,00</p>
--	--	---	------------------------------	-------------------

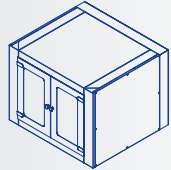
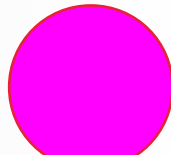
<p><b>Cella di lievitazione Proofer</b></p> 		<p>230 Volt AC 1/N/PE <b>800 W</b></p>	<p>20-60 °C</p>	<p>€ 1.527,00</p>
--	--	--	-----------------	-------------------

La cella di lievitazione non sostituisce il piedistallo ma è un modulo da inserire nel vano inferiore del piedistallo stesso.  
The proofer doesn't substitute the stand, it has to be placed inside the stand itself.

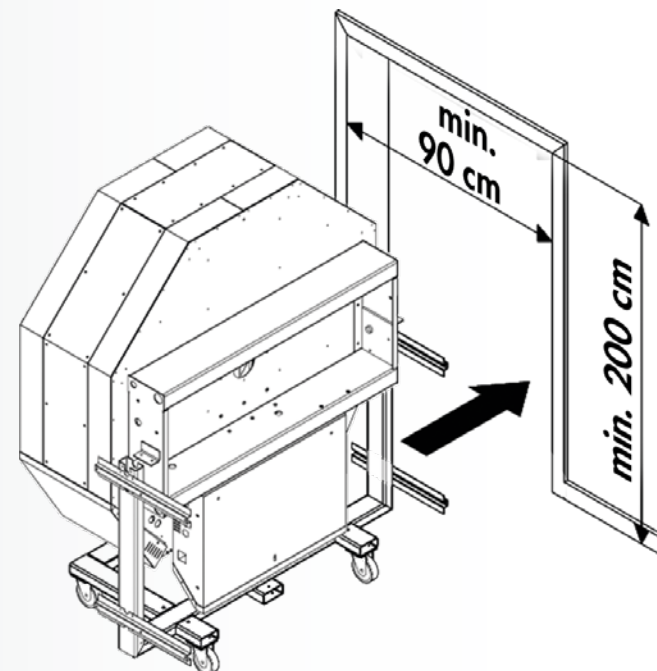

THE ONLY OVEN  
IN THE WORLD  
THAT BAKES WITH  
THE INNOVATIVE  
**IWOS™  
SYSTEM**  
Italian  
Wood  
Oven  
Substitute

# KING

## Innovativo sistema di cottura

### Innovative baking system



KING è l'unico forno al mondo che cuoce con l' **innovativo IWOS™ System (Italian Wood Oven Substitute)** che riproduce meccanicamente il movimento circolatorio dell'aria in un forno a legna.

#### COME FUNZIONA?

L'aria sottostante la pietra refrattaria viene riscaldata dalle resistenze e scorre verso l'alto attraverso una cavità, quindi viene incanalata dentro la camera di cottura direttamente sulle pizze attraverso apposite aperture. La pizza viene cotta da un mix di calore proveniente dalle resistenze e un flusso di aria bollente, **proprio come accade in un forno a legna.**

#### QUALI SONO I VANTAGGI PER IL PIZZAIOLO?

La circolazione dell'aria rispetto ad un classico forno statico si concretizza in una **pizza più simile a quella fatta in un forno a legna.** King è perciò un forno indicato a tutti i pizzaioli convinti che la pizza cotta in un forno a legna abbia un sapore migliore ma che non possono, per qualunque motivo, utilizzare questo tipo di forno.

**ATTENZIONE: 2 anni di garanzia su tutti i modelli (esclusa la centralina elettronica)**  
**WARNING: 2 years of warranty on all models (electronic board not included)**

*KING is the only oven in the world baking with the **innovative IWOS™ System (Italian Wood Oven Substitute)** which reproduces mechanically the air circulation inside a wood-burning pizza oven.*

#### HOW DOES IT WORK?

*The air below the refractory stone is heated by the heating elements and flows upwards through a cavity, then is channeled inside the baking chamber directly on pizzas through the holes in the bottom. Pizzas are baked thanks a combination of heat from top and below radiating the heating elements and the flow of heated air coming sideways, **exactly as it happens in the wood-burning pizza oven.***

#### WHICH ARE THE ADVANTAGES FOR THE PIZZA BAKER?

*The air circulation in KING makes the **pizza more similar to the one baked in a wood-burning pizza oven.** King is indicated for all the pizza bakers who think the pizza baked in a wood-burning pizza oven tastes better but cannot have, for any motive, such kind of oven.*

# La pizza come in un forno a legna

## The pizza like in a wood-burning pizza oven

#### INNOVATIVO

• Rivoluzionario sistema di cottura I.W.O.S (Italian Wood Oven Substitute)

#### PRATICO E ROBUSTO

• Modulare (si possono sovrapporre fino a 3 camere di cottura) • Completamente in acciaio inossidabile

#### PERFORMANTE

• Indicatore di temperatura • Controllo potenza di cielo e platea • Guaina sigillante per alte temperature per isolare al meglio la porta del forno • Piana refrattaria perfettamente liscia di facile pulitura, senza intercapedini dove farina e formaggio possono cadere e bruciare

#### INTELLIGENTE

• Possibilità di memorizzare fino a 9 programmi di cottura • Sistema elettronico che indica ed individua eventuali malfunzionamenti • Auto mode per programmare l'orario di accensione automatica • Pulsante economy per risparmiare energia quando non ci sono pizze in cottura

#### DURATURO

• Completamente in acciaio inossidabile • Garanzia estesa (2 anni)

#### INNOVATIVE

• Revolutionary I.W.O.S™ (Italian Wood Oven Substitute) Baking System

#### HANDY AND STURDY

• Modular (up to 3 baking chambers can be piled on) • Totally made of stainless steel

#### EXCELLENT PERFORMANCE

• Temperature display • Top and bottom power display • Sealing gasket for high temperature to insulate the door • No gap refractory stone, there is no difficult-to-clean sot where flour and cheese can get stuck, burn and ruin the taste of the pizza

#### SMART

• Possibility to store up to 9 baking programs • Dual control system that indicated any malfunctioning • Auto mode to set switching on time • Economy switch that allows to save energy when there is no pizza baking

#### LONG LASTING

• Totally made of stainless steel • Extended warranty (2 years)



**500°C**

**IWOS™  
SYSTEM**

pizze  
**4-6-9**  
pizzas

energia  
**-30%**  
energy

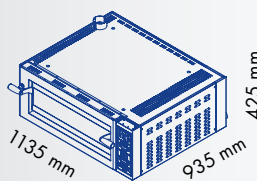
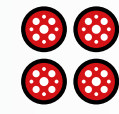
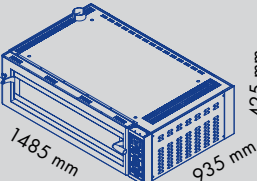
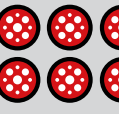
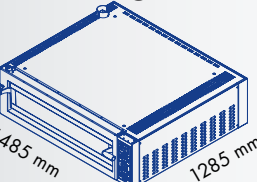

<p><b>KING 4</b></p>  <p>Dim. con manico e cavo Dim. with handle and cable 1135 x 1140 x 425 mm</p>	<p>n. pizze n. pizzas Ø 34 cm</p> 	<p>400 Volt AC 3/N/PE 230 Volt AC 1/N/PE 5,6 kW</p> <p>Misure interne camera LxPxH Chamber internal dimensions LxDxH 700 x 700 x 155 mm</p>	<p>60 - 500 °C</p> <p>167 kg TOP 182 kg</p>	<p>€ 4.378,00</p> <p>versione TOP TOP version € 4.742,00</p>
<p><b>KING 6G</b></p>  <p>Dim. con manico e cavo Dim. with handle and cable 1485 x 1140 x 425 mm</p>	<p>n. pizze n. pizzas Ø 34 cm</p> 	<p>400 Volt AC 3/N/PE 230 Volt AC 1/N/PE 10,4 kW</p> <p>Misure interne camera LxPxH Chamber internal dimensions LxDxH 1050 x 700 x 155 mm</p>	<p>60 - 500 °C</p> <p>192 kg TOP 217 kg</p>	<p>€ 4.656,00</p> <p>versione TOP TOP version € 5.130,00</p>
<p><b>KING 9</b></p>  <p>Dim. con manico e cavo Dim. with handle and cable 1485 x 1490 x 425 mm</p>	<p>n. pizze n. pizzas Ø 34 cm</p> 	<p>400 Volt AC 3/N/PE 230 Volt AC 1/N/PE 15,6 kW</p> <p>Misure interne camera LxPxH Chamber internal dimensions LxDxH 1050 x 1050 x 155 mm</p>	<p>60 - 500 °C</p> <p>265 kg TOP 296 kg</p>	<p>€ 5.259,00</p> <p>versione TOP TOP version € 5.868,00</p>

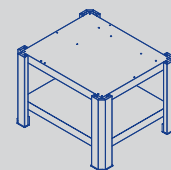
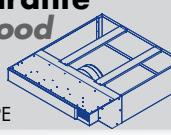
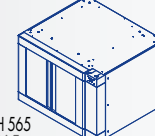
	<b>KING 4</b>	<b>KING 6G</b>	<b>KING 9</b>
<p><b>Piedistalli inox</b> Stainless steel stands</p> 	<p>1120x920x1165 mm (x 1 modulo) - Kg 82 € 1.176,00</p> <p>1120x920x965 mm (x 2 modulo) - Kg 72 € 1.145,00</p> <p>1120x920x565 mm (x 3 modulo) - Kg 62 € 1.115,00</p>	<p>1470x920x1165 mm (x 1 modulo) - Kg 98 € 1.287,00</p> <p>1470x920x965 mm (x 2 modulo) - Kg 88 € 1.257,00</p> <p>1470x920x565 mm (x 3 modulo) - Kg 78 € 1.227,00</p>	<p>1470x1270x1165 mm (x 1 modulo) - Kg 118 € 1.554,00</p> <p>1470x1270x965 mm (x 2 modulo) - Kg 108 € 1.524,00</p> <p>1470x1270x565 mm (x 3 modulo) - Kg 98 € 1.494,00</p>
<p><b>Kit portateglie (opzionale)</b> Baking trays rack (optional) non disponibile per piedistallo H 565 not available for stand H565</p>	<p>per 12 teglie for 12 trays € 506,00</p>	<p>per 12 teglie for 12 trays € 506,00</p>	<p>per 12 teglie for 12 trays € 506,00</p>
<p><b>Piano estraibile per piedistallo</b> Sliding table for stand non disponibile per piedistallo H 565 not available for stand H565</p>	<p>€ 299,00</p>	<p>€ 329,00</p>	<p>€ 389,00</p>
<p><b>Cappa neutra</b> Neutral hood</p>	<p>1135x1035x80 mm € 309,00</p>	<p>1485x1035x80 mm € 389,00</p>	<p>1485x1385x80 mm € 489,00</p>
<p><b>Cappa aspirante</b> Extractor hood 705 mc/h 0,11 kW 230 Volt AC 1/N/PE</p> 	<p>1135x1300x352 mm - 40 kg € 1.234,00</p>	<p>1485x1300x352 mm - 62 kg € 1.499,00</p>	<p>1485x1650x352 mm - 77 kg € 1.645,00</p>
<p><b>Cella di lievitazione</b> Proofer 230 Volt AC 1/N/PE 20-60 °C non disponibile per piedistallo a H 565 not available for stand H565</p> 	<p>Misure LxPxH Dimensions LxDxH 720x820x610 mm 800 W - 36 Kg € 1.527,00</p>	<p>Misure LxPxH Dimensions LxDxH 720x820x610 mm 800 W - 36 Kg € 1.527,00</p>	<p>Misure LxPxH Dimensions LxDxH 720x820x610 mm 800 W - 36 Kg € 1.527,00</p>

La cella di lievitazione non sostituisce il piedistallo ma è un modulo da inserire nel vano inferiore del piedistallo stesso.  
The proofer doesn't substitute the stand, it has to be placed inside the stand itself.



# AZZURRO BAKARY 2

# AZZURRO BAKARY 3



**PER PANE  
FOR BAKERY**

Disponibile solo  
con apertura verso l'alto

Available only  
with opening upwards

**460°C**

teglie  
**60x40**  
trays

energia  
**-30%**  
energy

Azzurro Bakery è **ideale per il piccolo panificio o per il ristorante** che vuole produrre il proprio **pane, croissant, biscotti** e molto altro.

Azzurro Bakery è stato progettato per il **risparmio energetico**. Ha un grande spessore di isolamento e nella versione a tre teglie è dotato di due porte che permettono di lavorare con la minima dispersione di calore.

Azzurro Bakery è **modulare**, permette perciò che vengano sovrapposte più camere. Può essere abbinato ad Azzurro Tray.

Azzurro Bakery is **ideal for a small bakery or restaurant** that wants to produce its own **bread, croissant, cookies** and much more.

Azzurro Bakery is engineered for **energy saving**. It has a thick insulation and in the three trays version has two independent doors that allow to work with a very low heat waste.

Azzurro Bakery is **modular**, therefore it allows to stack several chambers. It can be combined with Azzurro Tray.

**ATTENZIONE: 2 anni di garanzia su tutti i modelli (esclusa la centralina elettronica)**  
**WARNING: 2 years of warranty on all models (electronic board not included)**

La qualità **GAM International** ideale per il piccolo panificio o per il ristorante

*GAM International quality ideal for a small bakery or restaurant*



### RISPARMIO ENERGETICO

- 8 cm di isolamento che reduce al minimo la dispersione di calore
- Doppio vetro che sigilla il calore
- Guarnizione di tenuta per alte temperature per isolare la porta
- Pulsante economy per risparmiare energia quando il forno non è in uso

### ENERGY SAVING

- 8 cm thickness insulation that reduces drastically the heat waste
- Double glazing door (which insulates better)
- Sealing gasket for high temperature to insulate the door
- Economy switch that allows to save energy when the oven is not in use

### INTELLIGENTE

- Sistema di vaporizzazione dell'acqua incluso nel prezzo
- Tavolo estraibile costruito all'interno del piedistallo
- Piana in acciaio o su richiesta in refrattario
- Possibilità di memorizzare fino a 9 programmi di cottura
- Auto mode per programmare l'orario di accensione automatica

### SMART

- Vaporized water release system included in the price
- Large sliding table built inside the stand
- Stainless steel floor or on demand refractory stone one
- Possibility to store up to 9 baking programs
- Auto mode to set switching on time





### PERFORMANTE

- Altezza interna camera 25 cm
- Display per stabilire la durata di vaporizzazione dell'acqua
- Comoda ed ampia impugnatura ergonomica rotante che asseconda il movimento del polso
- Indicatore di temperatura
- Controllo potenza di cielo e platea
- Doppia lampada in ogni camera di cottura

### EXCELLENT PERFORMANCE

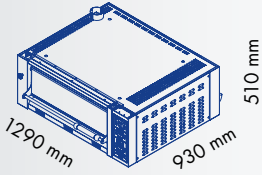
- Baking chamber internal height 25 cm
- Display allowing to set the length of vaporized water release
- Rotating ergonomic handle that follows the natural movement of the wrist
- Temperature display
- Top and bottom power display
- Double bulb in each baking chamber

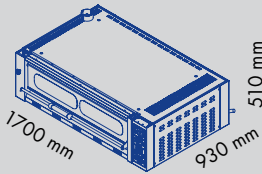

<p><b>AZZURRO BAKERY 2</b></p>  <p>1290 mm 930 mm 510 mm</p> <p>Dim. con manico e cavo Dim. with handle and cable 1290 x 1100 x 430 mm</p>	●	<p>n. 2 teglie n. 2 trays 60 x 40 cm</p> 	<p>400 Volt AC 3/N/PE 230 Volt AC 1/N/PE 6,0 kW</p> <p>Misure interne camera LxPxH Chamber internal dimensions LxDxH 835 x 615 x h=250 mm</p>	<p>60 - 460 °C</p> <p>175 kg</p>	<p>€ 5.184,00</p>
<p><b>AZZURRO BAKERY 3</b></p>  <p>1700 mm 930 mm 510 mm</p> <p>Dim. con manico e cavo Dim. with handle and cable 1700 x 1100 x 430 mm</p>	●	<p>n. 3 teglie n. 3 trays 60 x 40 cm</p> 	<p>400 Volt AC 3/N/PE 230 Volt AC 1/N/PE 9,0 kW</p> <p>Misure interne camera LxPxH Chamber internal dimensions LxDxH 1250 x 615 x h=250 mm</p>	<p>60 - 460 °C</p> <p>215 kg</p>	<p>€ 5.806,00</p>

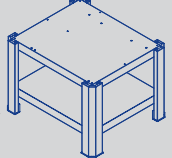
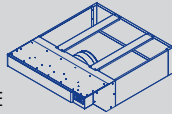
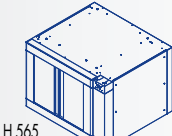
	<b>AZZURRO BAKERY 2</b>	<b>AZZURRO BAKERY 3</b>
<p><b>Piedistalli inox</b> Stainless steel stands</p> 	<p>Misure LxPxH Dimensions LxDxH 1280x920x1165 mm (x 1 modulo) - Kg 98 € 1.287,00 1280x920x965 mm (x 2 modulo) - Kg 88 € 1.257,00 1280x920x565 mm (x 3 modulo) - Kg 78 € 1.227,00</p>	<p>Misure LxPxH Dimensions LxDxH 1690x920x1165 mm (x 1 modulo) - Kg 98 € 1.554,00 1690x920x965 mm (x 2 modulo) - Kg 88 € 1.524,00 1690x920x565 mm (x 3 modulo) - Kg 78 € 1.494,00</p>
<p><b>Kit portateglie</b> (opzionale) Baking trays rack (optional) non disponibile per piedistallo a H 565 not available for stand H565</p>	<p>per 12 teglie for 12 trays € 506,00</p>	<p>per 12 teglie for 12 trays € 506,00</p>
<p><b>Piano estraibile per piedistallo</b> Sliding table for stand</p>	<p>€ 329,00</p>	<p>€ 389,00</p>
<p><b>Cappa neutra</b> Neutral hood</p>	<p>1290x1030x80 mm € 389,00</p>	<p>1700x1030x80 mm € 509,00</p>
<p><b>Cappa aspirante</b> Extractor hood</p> <p>705 mc/h 0,11 kW 230 Volt AC 1/N/PE</p> 	<p>1290 x 1290 x h=350 mm - 69 Kg € 1.499,00</p>	<p>1700 x 1290 x h=350 mm - 77 Kg € 1.645,00</p>
<p><b>Cella dilievitazione</b> Proofer</p> <p>230 Volt AC 1/N/PE 20-60 °C</p>  <p>non disponibile per piedistallo a H 565 not available for stand H565</p>	<p>Misure LxPxH Dimensions LxDxH 720x820x610 mm 800 W - 36 Kg € 1.527,00</p>	<p>Misure LxPxH Dimensions LxDxH 720x820x610 mm 800 W - 36 Kg € 1.527,00</p>

La cella di lievitazione non sostituisce il piedistallo ma è un modulo da inserire nel vano inferiore del piedistallo stesso.  
The proofer doesn't substitute the stand, it has to be placed inside the stand itself.



# AZZURRO TRAY 2

# AZZURRO TRAY 3



**PER PIZZA IN TEGLI  
FOR PIZZA TRAY**

Disponibile solo  
con apertura verso l'alto

Available only  
with opening upwards

**460°C**

teglie  
**60x40**  
trays

energia  
**-30%**  
energy

Azzurro Tray è pensato specificatamente per la produzione in **teglie 60x40**, è perciò ideale per la **realizzazione di pizze, focaccia in teglia e molto altro**.

Azzurro Tray è stato progettato per il **risparmio energetico**. Ha un grande spessore di isolamento e nella versione a tre teglie è dotato di due porte che permettono di lavorare con la minima dispersione di calore.

Azzurro Tray è **modulare**, permette perciò che vengano sovrapposte più camere. Può essere abbinato ad Azzurro Bakery.

Azzurro Tray has been thought for the production in **trays 60x40**, it is therefore **ideal for pizza and focaccia in trays and much more**.

Azzurro Tray is engineered for **energy saving**. It has a thick insulation and in the three trays version has two independent doors that allow to work with a very low heat waste.

Azzurro Tray is **modular**, therefore it allows to stack several chambers. It can be combined with Azzurro Bakery.

**ATTENZIONE: 2 anni di garanzia su tutti i modelli (esclusa la centralina elettronica)**  
**WARNING: 2 years of warranty on all models (electronic board not included)**

**La qualità GAM International per cuocere ogni tipo di impasto**  
**GAM International quality for baking all types of dough**



### RISPARMIO ENERGETICO

- 8 cm di isolamento che reduce al minimo la dispersione di calore
- Doppio vetro che sigilla il calore
- Guarnizione di tenuta per alte temperature per isolare la porta
- Pulsante economy per risparmiare energia quando il forno non è in uso

### ENERGY SAVING

- 8 cm thickness insulation that reduces drastically the heat waste
- Double glazing door (which insulates better)
- Sealing gasket for high temperature to insulate the door
- Economy switch that allows to save energy when the oven is not in use

### INTELLIGENTE

- Piedistallo in acciaio inox con piano estraibile (optional)
- Piana in acciaio o su richiesta in refrattario
- Possibilità di memorizzare fino a 9 programmi di cottura
- Sistema elettronico che indica ed individua eventuali malfunzionamenti
- Auto mode per programmare l'orario di accensione automatica

### SMART

- Stainless steel stand available with sliding table (optional)
- Stainless steel floor or on demand refractory stone one
- Possibility to store up to 9 baking programs
- Dual control system that indicated any malfunctioning
- Auto mode to set switching on time

### PERFORMANTE

- Comoda ed ampia impugnatura ergonomica rotante che asseconda il movimento del polso
- Indicatore di temperatura
- Controllo potenza di cielo e platea
- Doppia lampada in ogni camera di cottura

### EXCELLENT PERFORMANCE

- Rotating ergonomic handle that follows the natural movement of the wrist
- Temperature display
- Top and bottom power display
- Double bulb in each baking chamber

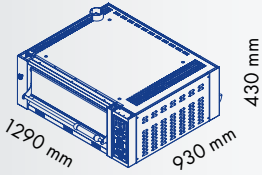
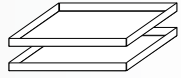
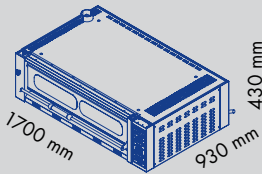
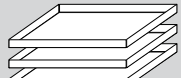

<p><b>AZZURRO TRAY 2</b></p>  <p>1290 mm 430 mm 930 mm</p> <p>Dim. con manico e cavo Dim. with handle and cable 1290 x 1100 x 430 mm</p>	●	<p>n. 2 teglie n. 2 trays 60 x 40 cm</p> 	<p>400 Volt AC 3/N/PE 230 Volt AC 1/N/PE 6,0 kW</p> <p>Misure interne camera LxPxH Chamber internal dimensions LxDxH 835 x 615 x h=180 mm</p>	<p>60 - 460 °C</p> <p>165 kg</p>	<p>€ 4.201,00</p>
<p><b>AZZURRO TRAY 3</b></p>  <p>1700 mm 430 mm 930 mm</p> <p>Dim. con manico e cavo Dim. with handle and cable 1700 x 1100 x 430 mm</p>	●	<p>n. 3 teglie n. 3 trays 60 x 40 cm</p> 	<p>400 Volt AC 3/N/PE 230 Volt AC 1/N/PE 9,0 kW</p> <p>Misure interne camera LxPxH Chamber internal dimensions LxDxH 1250 x 615 x h=180 mm</p>	<p>60 - 460 °C</p> <p>205 kg</p>	<p>€ 4.750,00</p>

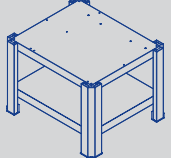
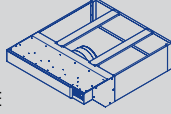
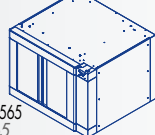
	<b>AZZURRO TRAY 2</b>	<b>AZZURRO TRAY 3</b>
<p><b>Piedistalli inox</b> Stainless steel stands</p> 	<p>Misure LxPxH Dimensions LxDxH 1280x920x1165 mm (x 1 modulo) - Kg 98 € 1.287,00 1280x920x965 mm (x 2 modulo) - Kg 88 € 1.257,00 1280x920x565 mm (x 3 modulo) - Kg 78 € 1.227,00</p>	<p>Misure LxPxH Dimensions LxDxH 1690x920x1165 mm (x 1 modulo) - Kg 98 € 1.554,00 1690x920x965 mm (x 2 modulo) - Kg 88 € 1.524,00 1690x920x565 mm (x 3 modulo) - Kg 78 € 1.494,00</p>
<p><b>Kit portateglie</b> (opzionale) Baking trays rack (optional)</p>	<p>per 12 teglie for 12 trays € 506,00</p>	<p>per 12 teglie for 12 trays € 506,00</p>
<p><b>Piano estraibile per piedistallo</b> Sliding table for stand</p>	<p>€ 329,00</p>	<p>€ 389,00</p>
<p><b>Cappa neutra</b> Neutral hood</p>	<p>1290x1030x80 mm € 389,00</p>	<p>1700x1030x80 mm € 509,00</p>
<p><b>Cappa aspirante</b> Extractor hood</p> <p>705 mc/h 0,11 kW 230 Volt AC 1/N/PE</p> 	<p>1290 x 1290 x h=350 mm - 69 Kg € 1.499,00</p>	<p>1700 x 1290 x h=350 mm - 77 Kg € 1.645,00</p>
<p><b>Cella di lievitazione</b> Proofer</p> <p>230 Volt AC 1/N/PE 20-60 °C</p> <p>non disponibile per piedistallo a H 565 not available for stand H565</p> 	<p>Misure LxPxH Dimensions LxDxH 720x820x610 mm 800 W - 36 Kg € 1.527,00</p>	<p>Misure LxPxH Dimensions LxDxH 720x820x610 mm 800 W - 36 Kg € 1.527,00</p>

La cella di lievitazione non sostituisce il piedistallo ma è un modulo da inserire nel vano inferiore del piedistallo stesso.  
The proofer doesn't substitute the stand, it has to be placed inside the stand itself.



# AZZURRO

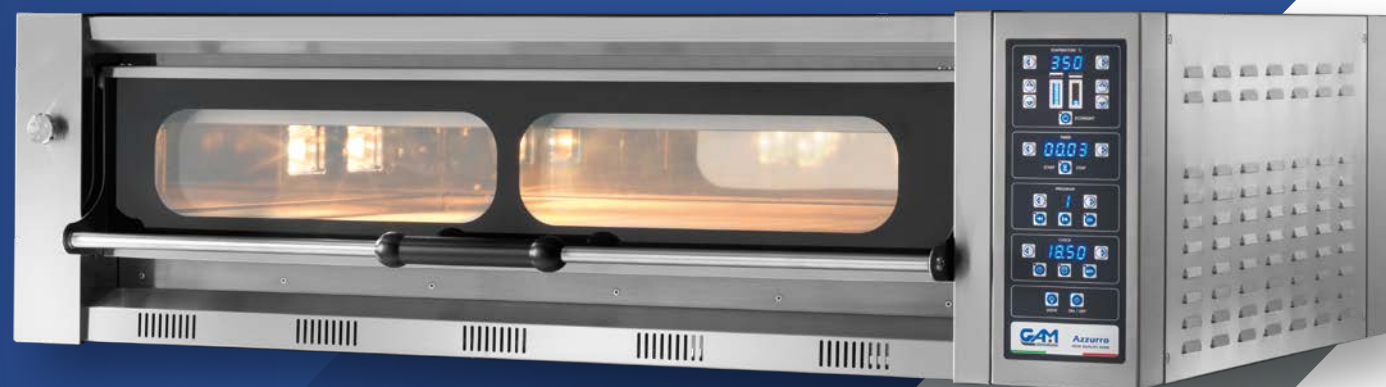

**460°C**

pizza  
**4-6-9**  
pizzas

energia  
**-30%**  
energy

Azzurro è il forno per pizza **ideale per il pizzaiolo che ha un locale di dimensioni ridotte**. L'apertura verso l'alto (a richiesta) permette di lavorare con pale corte e il piedistallo del forno è fornito di un robusto tavolo scorrevole che funge da piano di lavoro supplementare. Inoltre il forno è isolato con uno **strato di ben 8 cm di spessore di isolante** che donano prestazioni superiori al forno e un **concreto risparmio energetico**.

## QUALI SONO I VANTAGGI PER IL PIZZAIOLO?

Ideale per chi ha poco spazio e per chi lavora molto.

**ATTENZIONE: 2 anni di garanzia su tutti i modelli (esclusa la centralina elettronica)**  
**WARNING: 2 years of warranty on all models (electronic board not included)**

Azzurro is the pizza oven **ideal for the baker who has a small working place**. The door opening upwards (on demand) allows to work with shorter shovels and the stand provided with the oven has an extractible sliding table that provides an additional work surface. Furthermore the baking chamber is **insulated with a layer of extra-thick insulation of 8 cm** that allows outstanding baking performance and a **real energy saving**.

## WHICH ARE THE ADVANTAGES FOR THE PIZZA BAKER?

Ideally for the pizza baker who has little space and/or works a lot.

# Un grande forno per un piccolo spazio A magnificent oven for a small place

## RISPARMIO ENERGETICO

- 8 cm di isolamento che riduce al minimo la dispersione di calore
- Doppio vetro che sigilla il calore
- Guarnizione di tenuta per alte temperature per isolare la porta
- Camera di cottura ad altezza ridotta per riscaldare rapidamente e ridurre lo spreco di energia quando la porta è aperta
- Pulsante economy per risparmiare energia quando non ci sono pizze in cottura

## INTELLIGENTE

- Disponibile a richiesta con apertura verso l'alto (utile per spazi ristretti) o verso il basso (tradizionale)
- Disponibile con tavolo estraibile costruito all'interno del piedistallo
- Tavolo estraibile costruito all'interno del piedistallo
- Piana refrattaria perfettamente liscia di facile pulitura, senza intercapedini dove farina e formaggio possono cadere e bruciare
- Possibilità di memorizzare fino a 9 programmi di cottura
- Sistema elettronico che indica ed individua eventuali malfunzionamenti
- Auto mode per programmare l'orario di accensione automatica
- Modulare (si possono sovrapporre fino a 3 camere di cottura)



## PERFORMANTE

- Raggiunge velocemente la temperatura di lavoro, raggiunge 300°C in meno di 30 minuti e 460° in meno di 50 minuti
- Comoda ed ampia impugnatura ergonomica rotante che asseconda il movimento del polso
- Indicatore di temperatura
- Controllo potenza di cielo e platea
- Doppia lampada in ogni camera di cottura

## DURATURO

- Completamente in acciaio inossidabile
- Garanzia estesa (2 anni)

## ENERGY SAVING

- 8 cm thickness insulation that reduces drastically the heat waste
- Double glazing door (which insulates better)
- Sealing gasket for high temperature to insulate the door
- Low baking chamber for quickly warming the baking chamber and reduce the waste of energy when the door is open
- Economy switch that allows to save energy when there is no pizza baking

## SMART

- Available with opening up (useful for confined spaces) or down (traditional)
- Available with large sliding table built inside the stand
- No gap refractory stone, there is no difficult-to-clean spot where flour and cheese can get stuck, burn and ruin the taste of the pizza
- Possibility to store up to 9 baking programs
- Dual control system that indicated any malfunctioning
- Auto mode to set switching on time
- Modular (up to 3 baking chambers can be piled on)





## EXCELLENT PERFORMANCE

- It reaches quickly the working temperature, 300°C in less than 30 minutes and 460° in less than 50 minutes, allowing to bake any kind of pizza or bakery product
- Rotating ergonomic handle that follows the natural movement of the wrist
- Temperature display
- Top and bottom power display
- Double bulb in each baking chamber

## LONG LASTING

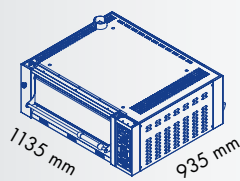
- Totally made of stainless steel
- Extended warranty (2 years)

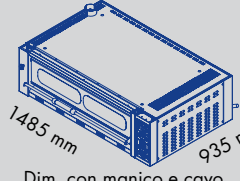
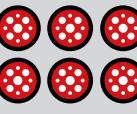
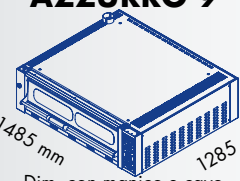

<p><b>AZZURRO 4</b></p>  <p>1135 mm 935 mm 425 mm</p> <p>Dim. con manico e cavo Dim. with handle and cable 1135 x 1090 x 425 mm</p>	<p>n. pizze n. pizzas Ø 34 cm</p> 	<p>⚡ 400 Volt AC 3/N/PE 230 Volt AC 1/N/PE 5,6 kW</p> <p>Misure interne camera LxPxH Chamber internal dimensions LxDxH 700 x 700 x 155 mm</p>	<p>🌡️ 60 - 460 °C</p> <p>🔌 167 kg TOP 182 kg</p>	<p>€ 3.139,00</p> <p>versione TOP TOP version € 3.438,00</p>
<p><b>AZZURRO 6</b></p>  <p>1485 mm 935 mm 425 mm</p> <p>Dim. con manico e cavo Dim. with handle and cable 1485 x 1090 x 425 mm</p>	<p>n. pizze n. pizzas Ø 34 cm</p> 	<p>⚡ 400 Volt AC 3/N/PE 230 Volt AC 1/N/PE 10,4 kW</p> <p>Misure interne camera LxPxH Chamber internal dimensions LxDxH 1050 x 700 x 155 mm</p>	<p>🌡️ 60 - 460 °C</p> <p>🔌 192 kg TOP 217 kg</p>	<p>€ 3.639,00</p> <p>versione TOP TOP version € 4.004,00</p>
<p><b>AZZURRO 9</b></p>  <p>1485 mm 1285 mm 425 mm</p> <p>Dim. con manico e cavo Dim. with handle and cable 1485 x 1440 x 425 mm</p>	<p>n. pizze n. pizzas Ø 34 cm</p> 	<p>⚡ 400 Volt AC 3/N/PE 230 Volt AC 1/N/PE 15,6 kW</p> <p>Misure interne camera LxPxH Chamber internal dimensions LxDxH 1050 x 1050 x 155 mm</p>	<p>🌡️ 60 - 460 °C</p> <p>🔌 265 kg TOP 296 kg</p>	<p>€ 4.339,00</p> <p>versione TOP TOP version € 4.818,00</p>

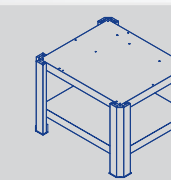
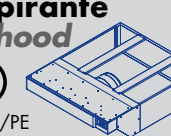
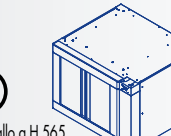
	<b>AZZURRO 4</b>	<b>AZZURRO 6</b>	<b>AZZURRO 9</b>
<p><b>Piedistalli inox</b> <i>Stainless steel stands</i></p> 	<p>1120x920x1165 mm (x 1 modulo) - Kg 82 € 1.175,00</p> <p>1120x920x965 mm (x 2 modulo) - Kg 72 € 1.145,00</p> <p>1120x920x565 mm (x 3 modulo) - Kg 62 € 1.115,00</p>	<p>1470x920x1165 mm (x 1 modulo) - Kg 98 € 1.287,00</p> <p>1470x920x965 mm (x 2 modulo) - Kg 88 € 1.257,00</p> <p>1470x920x565 mm (x 3 modulo) - Kg 78 € 1.227,00</p>	<p>1470x1270x1165 mm (x 1 modulo) - Kg 118 € 1.554,00</p> <p>1470x1270x965 mm (x 2 modulo) - Kg 108 € 1.524,00</p> <p>1470x1270x565 mm (x 3 modulo) - Kg 98 € 1.494,00</p>
<p><b>Kit portateglie (opzionale)</b> <i>Baking trays rack (optional)</i> non disponibile per piedistallo H 565 not available for stand H565</p>	<p>per 12 teglie for 12 trays € 506,00</p>	<p>per 12 teglie for 12 trays € 506,00</p>	<p>per 12 teglie for 12 trays € 506,00</p>
<p><b>Piano estraibile per piedistallo</b> <i>Sliding table for stand</i> non disponibile per piedistallo H 565 not available for stand H565</p>	<p>€ 299,00</p>	<p>€ 329,00</p>	<p>€ 389,00</p>
<p><b>Cappa neutra</b> <i>Neutral hood</i></p>	<p>1135x1035x80 mm € 309,00</p>	<p>1485x1035x80 mm € 389,00</p>	<p>1485x1385x80 mm € 489,00</p>
<p><b>Cappa aspirante</b> <i>Extractor hood</i> 705 mc/h 0,11 kW 230 Volt AC 1/N/PE</p> 	<p>1135x1300x352 mm - 40 kg € 1.234,00</p>	<p>1485x1300x352 mm - 62 kg € 1.499,00</p>	<p>1485x1650x352 mm - 77 kg € 1.645,00</p>
<p><b>Cella di lievitazione</b> <i>Proofer</i> 230 Volt AC 1/N/PE 20-60 °C non disponibile per piedistallo a H 565 not available for stand H565</p> 	<p>Misure LxPxH Dimensions LxDxH 720x820x610 mm 800 W - 36 Kg € 1.527,00</p>	<p>Misure LxPxH Dimensions LxDxH 720x820x610 mm 800 W - 36 Kg € 1.527,00</p>	<p>Misure LxPxH Dimensions LxDxH 720x820x610 mm 800 W - 36 Kg € 1.527,00</p>

La cella di lievitazione non sostituisce il piedistallo ma è un modulo da inserire nel vano inferiore del piedistallo stesso.  
The proofer doesn't substitute the stand, it has to be placed inside the stand itself.



**ME**



**420°C**

pizze  
**4-6-9**  
pizzas

**elettronico**  
**electronic**

Il forno pizza ME è un forno digitale **altamente performante, economico, facile da usare, a risparmio energetico e sicuro.**

Il forno è completamente fatto di acciaio inossidabile ed è **perfettamente isolato, è sicuro, facile da usare e da pulire.**

*The ME pizza oven has been engineered to be a highly performing digital oven that is affordable, easy, energy saving and safe.*

*The oven is made of long lasting stainless steel and perfectly insulated, it is safe, easy to use and to clean.*



pannello comandi elettronico

electronic control board

## Un classico forno elettronico di qualità A classic electronic pizza oven of quality

### CARATTERISTICHE PRINCIPALI

- Elettronico
- Totalmente in acciaio inossidabile
- Modulare (si possono sovrapporre fino a 3 camere di cottura)
- Possibilità di memorizzare fino a 9 programmi di cottura
- Porta rimovibile per facilitare la pulizia
- Guaina sigillante per alte temperature per isolare al meglio la porta del forno
- Isolamento a fibra di vetro
- Pulsante economy per risparmiare energia quando non ci sono pizze in cottura
- Porta in doppio vetro per evitare scottature
- Controllo temperatura cielo e platea
- Timer e segnalatore acustico
- Indicatore di temperatura
- Pietra refrattaria rettificata
- Scarico fumi regolabile
- Auto mode per programmare l'orario di accensione automatica





### MAIN FEATURES

- Electronic
- Totally made of stainless steel
- Modular (up to 3 baking chambers can be piled on)
- Possibility to store up to 9 baking programs
- Removable door to ease cleaning
- Sealing gasket for high temperature to insulate the door
- Glass fiber insulation
- Economy switch that allows to save energy when there is no pizza baking
- Double glazing door to prevent burn
- Top and bottom heat control
- Timer and alarm
- Temperature display
- No gap refractory stone
- Adjustable exhaust fumes
- Auto mode to set the switching on time

versione TOP (rivestimento totale in refrattario)  
TOP version (fully refractory stone covered baking chamber)

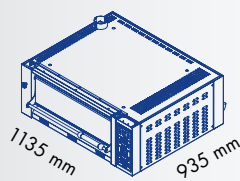

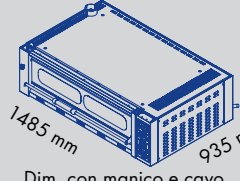
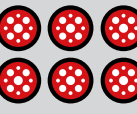
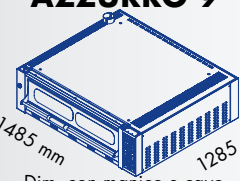
**ATTENZIONE: 2 anni di garanzia su tutti i modelli (esclusa la centralina elettronica)**  
**WARNING: 2 years of warranty on all models (electronic board not included)**

<p><b>AZZURRO 4</b></p>  <p>1135 mm 935 mm 425 mm</p> <p>Dim. con manico e cavo Dim. with handle and cable 1135 x 1090 x 425 mm</p>	<p>n. pizze n. pizzas Ø 34 cm</p> 	<p>⚡</p> <p>400 Volt AC 3/N/PE 230 Volt AC 1/N/PE 5,6 kW</p> <p>Misure interne camera LxPxH Chamber internal dimensions LxDxH 700 x 700 x 155 mm</p> <p>🌡️</p> <p>60 - 460 °C</p> <p>🔒</p> <p>167 kg TOP 182 kg</p>	<p>€ 3.139,00</p> <p>versione TOP TOP version € 3.438,00</p>
<p><b>AZZURRO 6</b></p>  <p>1485 mm 935 mm 425 mm</p> <p>Dim. con manico e cavo Dim. with handle and cable 1485 x 1090 x 425 mm</p>	<p>n. pizze n. pizzas Ø 34 cm</p> 	<p>⚡</p> <p>400 Volt AC 3/N/PE 230 Volt AC 1/N/PE 10,4 kW</p> <p>Misure interne camera LxPxH Chamber internal dimensions LxDxH 1050 x 700 x 155 mm</p> <p>🌡️</p> <p>60 - 460 °C</p> <p>🔒</p> <p>192 kg TOP 217 kg</p>	<p>€ 3.639,00</p> <p>versione TOP TOP version € 4.004,00</p>
<p><b>AZZURRO 9</b></p>  <p>1485 mm 1285 mm 425 mm</p> <p>Dim. con manico e cavo Dim. with handle and cable 1485 x 1440 x 425 mm</p>	<p>n. pizze n. pizzas Ø 34 cm</p> 	<p>⚡</p> <p>400 Volt AC 3/N/PE 230 Volt AC 1/N/PE 15,6 kW</p> <p>Misure interne camera LxPxH Chamber internal dimensions LxDxH 1050 x 1050 x 155 mm</p> <p>🌡️</p> <p>60 - 460 °C</p> <p>🔒</p> <p>265 kg TOP 296 kg</p>	<p>€ 4.339,00</p> <p>versione TOP TOP version € 4.818,00</p>

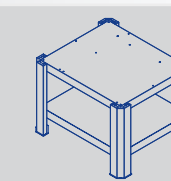
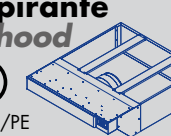
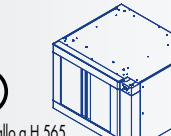
	<b>AZZURRO 4</b>	<b>AZZURRO 6</b>	<b>AZZURRO 9</b>
<p><b>Piedistalli inox</b> <i>Stainless steel stands</i></p> 	<p>1120x920x1165 mm (x 1 modulo) - Kg 82 € 1.175,00</p> <p>1120x920x965 mm (x 2 modulo) - Kg 72 € 1.145,00</p> <p>1120x920x565 mm (x 3 modulo) - Kg 62 € 1.115,00</p>	<p>1470x920x1165 mm (x 1 modulo) - Kg 98 € 1.287,00</p> <p>1470x920x965 mm (x 2 modulo) - Kg 88 € 1.257,00</p> <p>1470x920x565 mm (x 3 modulo) - Kg 78 € 1.227,00</p>	<p>1470x1270x1165 mm (x 1 modulo) - Kg 118 € 1.554,00</p> <p>1470x1270x965 mm (x 2 modulo) - Kg 108 € 1.524,00</p> <p>1470x1270x565 mm (x 3 modulo) - Kg 98 € 1.494,00</p>
<p><b>Kit portateglie (opzionale)</b> <i>Baking trays rack (optional)</i></p> <p>non disponibile per piedistallo H 565 not available for stand H565</p>	<p>per 12 teglie for 12 trays € 506,00</p>	<p>per 12 teglie for 12 trays € 506,00</p>	<p>per 12 teglie for 12 trays € 506,00</p>
<p><b>Piano estraibile per piedistallo</b> <i>Sliding table for stand</i></p> <p>non disponibile per piedistallo H 565 not available for stand H565</p>	<p>€ 299,00</p>	<p>€ 329,00</p>	<p>€ 389,00</p>
<p><b>Cappa neutra</b> <i>Neutral hood</i></p>	<p>1135x1035x80 mm € 309,00</p>	<p>1485x1035x80 mm € 389,00</p>	<p>1485x1385x80 mm € 489,00</p>
<p><b>Cappa aspirante</b> <i>Extractor hood</i></p> <p>705 mc/h 0,11 kW 230 Volt AC 1/N/PE</p> 	<p>1135x1300x352 mm - 40 kg € 1.234,00</p>	<p>1485x1300x352 mm - 62 kg € 1.499,00</p>	<p>1485x1650x352 mm - 77 kg € 1.645,00</p>
<p><b>Cella di lievitazione</b> <i>Proofer</i></p> <p>230 Volt AC 1/N/PE 20-60 °C non disponibile per piedistallo a H 565 not available for stand H565</p> 	<p>Misure LxPxH Dimensions LxDxH 720x820x610 mm 800 W - 36 Kg € 1.527,00</p>	<p>Misure LxPxH Dimensions LxDxH 720x820x610 mm 800 W - 36 Kg € 1.527,00</p>	<p>Misure LxPxH Dimensions LxDxH 720x820x610 mm 800 W - 36 Kg € 1.527,00</p>

La cella di lievitazione non sostituisce il piedistallo ma è un modulo da inserire nel vano inferiore del piedistallo stesso.  
The proofer doesn't substitute the stand, it has to be placed inside the stand itself.



**M**



**450°C**

pizze  
**4-6-9**  
pizzas

Il forno M è un forno elettromeccanico **altamente performante, economico, facile da usare, a risparmio energetico e sicuro.**

Il forno è completamente fatto di acciaio inossidabile ed è **perfettamente isolato, è sicuro, facile da usare e da pulire.**

*The M pizza oven has been engineered to be a **highly performing mechanical oven, easy, energy saving and safe.** The oven is made of long lasting stainless steel and **perfectly insulated, it is safe, easy to use and to clean.***



disponibile anche con cappa aspirante  
available also with extractor hood

## Forno per pizza elettromeccanico di qualità *Electromechanical pizza oven of quality*

### CARATTERISTICHE PRINCIPALI

- Meccanico
- Totalmente in acciaio inossidabile
- Camere di cottura in acciaio inox
- Modulare (si possono sovrapporre fino a 3 camere di cottura)
- Porta rimovibile per facilitare la pulizia
- Guaina sigillante per alte temperature per isolare al meglio la porta del forno
- Isolamento a fibra di vetro
- Porta in doppio vetro per evitare scottature
- Pietra refrattaria rettificata
- Scarico fumi regolabile
- Interruttore generale di accensione







### MAIN FEATURES

- Electromechanical
- Totally made of stainless steel
- Baking chamber made of stainless steel
- Modular (up to 3 baking chambers can be piled on)
- Removable door to ease cleaning
- Sealing gasket for high temperature to insulate the door
- Glass fiber insulation
- Double glazing door to prevent burn
- No gap refractory stone
- Adjustable exhaust fumes
- Main power switch

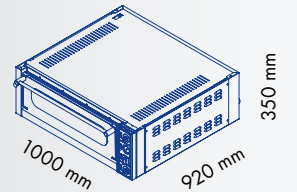
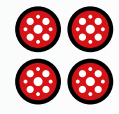
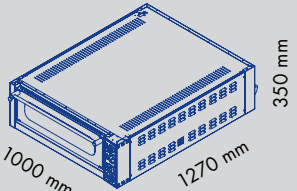

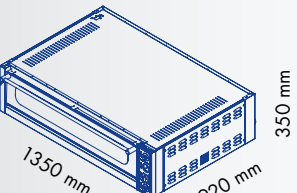
versione TOP (rivestimento totale in refrattario)  
TOP version (fully refractory stone covered baking chamber)

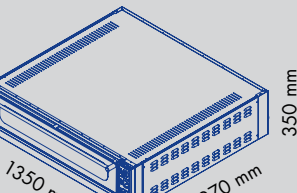
**ATTENZIONE: 2 anni di garanzia su tutti i modelli (esclusa la centralina elettronica)**  
**WARNING: 2 years of warranty on all models (electronic board not included)**

<p><b>M4 M4 TOP</b></p>  <p>1000 mm 920 mm 350 mm</p> <p>Dim. con manico e cavo Dim. with handle and cable 1000 x 990 x 350 mm</p>	<p>n. pizze n. pizzas Ø 34 cm</p> 	<p>⚡</p> <p>400 Volt AC 3/N/PE 230 Volt AC 1/N/PE 4,8 kW</p> <p>Misure interne / Internal dimensions LxPxH 700 x 700 x 145 mm</p> <p>Versione TOP / TOP version LxPxH 670 x 685 x 145 mm</p>	<p>🌡️</p> <p>60 - 450 °C</p> <p>🔌</p> <p>73 kg TOP 91 kg</p>	<p>€ 1.795,00</p> <p>versione TOP TOP version € 2.158,00</p>
<p><b>M6 M6 TOP</b></p>  <p>1000 mm 1270 mm 350 mm</p> <p>Dim. con manico e cavo Dim. with handle and cable 1000 x 1340 x 350 mm</p>	<p>n. pizze n. pizzas Ø 34 cm</p> 	<p>⚡</p> <p>400 Volt AC 3/N/PE 230 Volt AC 1/N/PE 7,2 kW</p> <p>Misure interne / Internal dimensions LxPxH 700 x 1050 x 145 mm</p> <p>Versione TOP / TOP version LxPxH 670 x 1035 x 145 mm</p>	<p>🌡️</p> <p>60 - 450 °C</p> <p>🔌</p> <p>102 kg TOP 127 kg</p>	<p>€ 2.107,00</p> <p>versione TOP TOP version € 2.566,00</p>
<p><b>M6G M6G TOP</b></p>  <p>1350 mm 920 mm 350 mm</p> <p>Dim. con manico e cavo Dim. with handle and cable 1350 x 990 x 350 mm</p>	<p>n. pizze n. pizzas Ø 34 cm</p> 	<p>⚡</p> <p>400 Volt AC 3/N/PE 230 Volt AC 1/N/PE 8,8 kW</p> <p>Misure interne / Internal dimensions LxPxH 1050 x 700 x 145 mm</p> <p>Versione TOP / TOP version LxPxH 1020 x 685 x 145 mm</p>	<p>🌡️</p> <p>60 - 450 °C</p> <p>🔌</p> <p>110 kg TOP 134 kg</p>	<p>€ 2.285,00</p> <p>versione TOP TOP version € 2.758,00</p>
<p><b>M9 M9 TOP</b></p>  <p>1350 mm 1270 mm 350 mm</p> <p>Dim. con manico e cavo Dim. with handle and cable 1350 x 1340 x 350 mm</p>	<p>n. pizze n. pizzas Ø 34 cm</p> 	<p>⚡</p> <p>400 Volt AC 3/N/PE 230 Volt AC 1/N/PE 13,2 kW</p> <p>Misure interne / Internal dimensions LxPxH 1050 x 1050 x 145 mm</p> <p>Versione TOP / TOP version LxPxH 1020 x 1035 x 145 mm</p>	<p>🌡️</p> <p>60 - 450 °C</p> <p>🔌</p> <p>136 kg TOP 172 kg</p>	<p>€ 3.178,00</p> <p>versione TOP TOP version € 3.785,00</p>

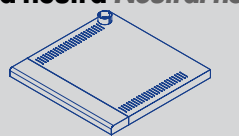
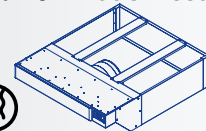
	<b>M4 M4 TOP</b>	<b>M6 M6 TOP</b>	<b>M6G M6G TOP</b>	<b>M9 M9 TOP</b>
<p><b>Cappa neutra Neutral hood</b></p> 	<p>Misure LxPxH Dimensions LxDxH 1000 x 976 x 70 mm</p> <p>€ 255,00</p>	<p>Misure LxPxH Dimensions LxDxH 1000 x 1326 x 70 mm</p> <p>€ 305,00</p>	<p>Misure LxPxH Dimensions LxDxH 1350 x 976 x 70 mm</p> <p>€ 315,00</p>	<p>Misure LxPxH Dimensions LxDxH 1350 x 1326 x 70 mm</p> <p>€ 435,00</p>
<p><b>Cappa aspirante Extractor hood</b></p> <p>230 Volt AC 1/N/PE 0,051 kW 218 mc /h</p> 	<p>Misure LxPxH Dimensions LxDxH 1000 x 1210 x 270 mm</p> <p>29 kg € 865,00</p>	<p>Misure LxPxH Dimensions LxDxH 1000 x 1560 x 270 mm</p> <p>31 kg € 932,00</p>	<p>Misure LxPxH Dimensions LxDxH 1360 x 1210 x 270 mm</p> <p>32 kg € 965,00</p>	<p>Misure LxPxH Dimensions LxDxH 1360 x 1560 x 270 mm</p> <p>36 kg € 999,00</p>



# MD



**450°C**

pizze  
**4-6**  
**8-12**  
pizzas

Il forno MD è un forno elettromeccanico **altamente performante, facile da usare, a risparmio energetico e sicuro**. Il forno ha la camera di cottura completamente in acciaio inossidabile ed è **perfettamente isolato, è sicuro, facile da usare e da pulire**. La struttura esterna, (fianchi, tetto e schiena) è realizzata in lamiera preverniciata. Disponibile nelle sole **versioni monoblocco a una o due camere**.

*The MD pizza oven has been engineered to be a **highly performing electromechanical oven, easy, energy saving and safe**. The oven has the baking chamber made of long lasting stainless steel and **perfectly insulated, it is safe, easy to use and to clean**. The external structure (sides, roof and back) is made of painted sheet. Available in single block versions only, either **with one or two chambers**.*

**ATTENZIONE: 2 anni di garanzia su tutti i modelli (esclusa la centralina elettronica)**  
**WARNING: 2 years of warranty on all models (electronic board not included)**

## Forno per pizza elettromeccanico di qualità *Electromechanical pizza oven of quality*

### CARATTERISTICHE PRINCIPALI

- Elettromeccanico
- La struttura esterna, (fianchi, tetto e schiena) è realizzata in lamiera preverniciata.
- Camere di cottura in acciaio inox
- Disponibile nelle sole versioni monoblocco
- Porta rimovibile per facilitare la pulizia
- Guaina sigillante per alte temperature per isolare al meglio la porta del forno
- Isolamento a fibra di vetro
- Porta a doppio vetro con copertura in acciaio inox
- Pietra refrattaria rettificata
- Apertura e chiusura dell' uscita fumi meccanica
- Interruttore generale di accensione

### MAIN FEATURES

- *Electromechanical*
- *The external structure (sides, roof and back) is made of painted sheet.*
- *Baking chamber made of stainless steel*
- *Available in single block versions only*
- *Removable door to ease cleaning*
- *Sealing gasket for high temperature to insulate the door*
- *Glass fiber insulation*
- *Double glazing door with stainless steel cover*
- *No gap refractory stone*
- *Adjustable exhaust fumes*
- *Main power switch*



scarico fumi regolabile  
*adjustable exhaust fumes disposal*

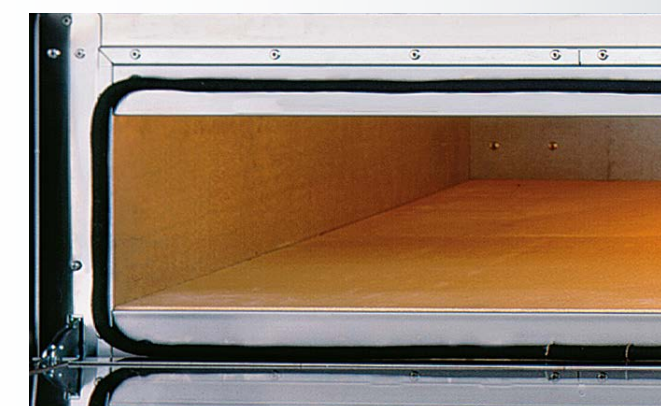

tutti i forni della serie MD sono disponibili anche nella versione TOP, ossia completamente in refrattario.

*all ovens MD are available also in the TOP version, completely in refractory stone.*

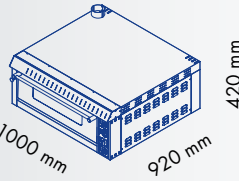
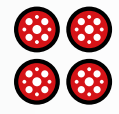
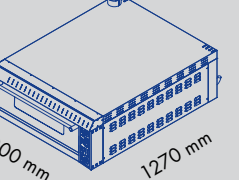
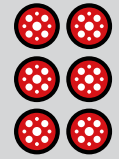
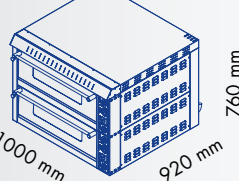
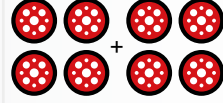
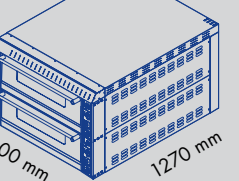
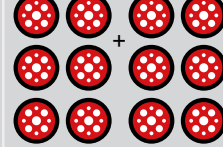
<p><b>MD4 MD4 TOP</b></p>  <p>1000 mm 920 mm 420 mm</p> <p>Dim. con manico e cavo Dim. with handle and cable 1000 x 990 x 420 mm</p>	●	<p>n. pizze n. pizzas Ø 34 cm</p> 	<p>⚡</p> <p>400 Volt AC 3/N/PE 230 Volt AC 1/N/PE 4,8 kW</p> <p>Misure interne / Internal dimensions LxPxH 700 x 700 x 145 mm</p> <p>Versione TOP / TOP version LxPxH 670 x 685 x 145 mm</p>	<p>🌡️</p> <p>60 - 450 °C</p> <p>🔌</p> <p>80 kg TOP 98 kg</p>	<p>€ 1.727,00</p> <p>versione TOP TOP version € 2.090,00</p>
<p><b>MD6 MD6 TOP</b></p>  <p>1000 mm 1270 mm 420 mm</p> <p>Dim. con manico e cavo Dim. with handle and cable 1000 x 1340 x 420 mm</p>	●	<p>n. pizze n. pizzas Ø 34 cm</p> 	<p>⚡</p> <p>400 Volt AC 3/N/PE 230 Volt AC 1/N/PE 7,2 kW</p> <p>Misure interne / Internal dimensions LxPxH 700 x 1050 x 145 mm</p> <p>Versione TOP / TOP version LxPxH 670 x 1035 x 145 mm</p>	<p>🌡️</p> <p>60 - 450 °C</p> <p>🔌</p> <p>102 kg TOP 127 kg</p>	<p>€ 2.035,00</p> <p>versione TOP TOP version € 2.494,00</p>
<p><b>MD44 MD44 TOP</b></p>  <p>1000 mm 920 mm 760 mm</p> <p>Dim. con manico e cavo Dim. with handle and cable 1000 x 990 x 760 mm</p>	●	<p>n. pizze n. pizzas Ø 34 cm</p> 	<p>⚡</p> <p>400 Volt AC 3/N/PE 230 Volt AC 1/N/PE 9,6 kW</p> <p>Misure interne / Internal dimensions LxPxH 700 x 700 x 145 mm</p> <p>Versione TOP / TOP version LxPxH 670 x 685 x 145 mm</p>	<p>🌡️</p> <p>60 - 450 °C</p> <p>🔌</p> <p>142 kg TOP 178 kg</p>	<p>€ 3.076,00</p> <p>versione TOP TOP version € 3.802,00</p>
<p><b>MD66 MD66 TOP</b></p>  <p>1000 mm 1270 mm 760 mm</p> <p>Dim. con manico e cavo Dim. with handle and cable 1000 x 1340 x 760 mm</p>	●	<p>n. pizze n. pizzas Ø 34 cm</p> 	<p>⚡</p> <p>400 Volt AC 3/N/PE 230 Volt AC 1/N/PE 14,4 kW</p> <p>Misure interne / Internal dimensions LxPxH 700 x 1050 x 145 mm</p> <p>Versione TOP / TOP version LxPxH 670 x 1035 x 145 mm</p>	<p>🌡️</p> <p>60 - 450 °C</p> <p>🔌</p> <p>193 kg TOP 243 kg</p>	<p>€ 3.511,00</p> <p>versione TOP TOP version € 4.429,00</p>

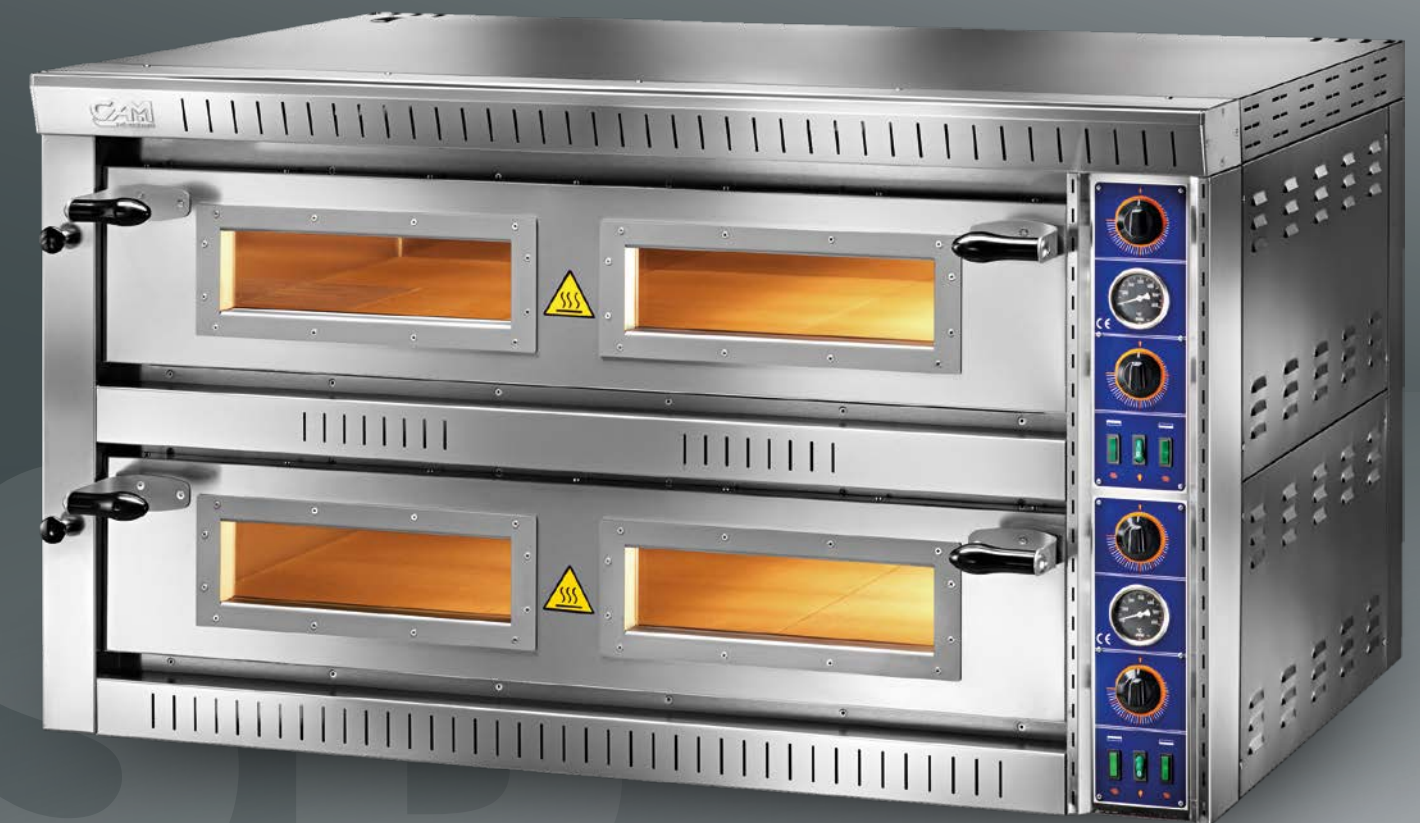

# SB Forno per pizza elettromeccanico Electromechanical pizza oven



SB è una linea di forni con un buon rapporto qualità prezzo e si posiziona in una fascia leggermente inferiore alle linee M e MD. **È indicato per chi vuole un buon forno ad un ottimo prezzo.**

## CARATTERISTICHE PRINCIPALI

- Elettromeccanico
- La struttura esterna, (fianchi, tetto e schiena) è realizzata in lamiera preverniciata.
- Camere di cottura in acciaio inox
- Disponibile nelle sole versioni monoblocco
- Porta rimovibile per facilitare la pulizia
- Isolamento a fibra di vetro
- Porta in acciaio inox
- Pietra refrattaria rettificata
- Apertura e chiusura dell' uscita fumi meccanica

*The SB is a line of ovens with good quality/price value and is located slightly below the lines M and MD. It is suitable for those who want a good oven at a great price.*

## MAIN FEATURES

- Electromechanical
- The external structure (sides, roof and back) is made of painted sheet.
- Baking chamber made of stainless steel
- Available in single block versions only
- Removable door to ease cleaning
- Glass fiber insulation
- Stainless steel door
- No gap refractory stone
- Adjustable exhaust fumes

## La linea SB disponibile anche nella versione TOP

Oltre alla piana di cottura, tutte le altre superfici della camera sono rivestite dalla piana refrattaria. Grazie al rivestimento in refrattario il risultato di cottura è migliore, e la temperatura viene mantenuta meglio, e il consumo notevolmente ridotto.

## The line SB is also available in TOP version

In addition to the cooking surface, all other surfaces of the chamber are covered by refractory stones. Thanks to the refractory coating, the baking result is better, the temperature is preserved better, and the consumption is greatly reduced.



**ATTENZIONE: 2 anni di garanzia su tutti i modelli (esclusa la centralina elettronica)**  
**WARNING: 2 years of warranty on all models (electronic board not included)**

<p><b>SB4 - SB4 TOP</b></p> <p>Dim. con manico e cavo Dim. with handle and cable 1000 x 1100 x 430 mm</p>	<p>n. pizze n. pizzas Ø 34 cm</p>	<p>400 Volt AC 3/N/PE 230 Volt AC 1/N/PE 4,8 kW</p> <p>Misure interne camera LxPxH Chamber internal dimensions LxDxH 700 x 700 x 145 mm</p> <p>Versione TOP / TOP version LxPxH 670 x 685 x 145 mm</p>	<p>60 - 450 °C</p> <p>80 kg TOP 98 kg</p> <p>€ 1.529,00</p> <p>versione TOP TOP version € 1.892,00</p>
<p><b>SB6 - SB6 TOP</b></p> <p>Dim. con manico e cavo Dim. with handle and cable 1000 x 1450 x 430 mm</p>	<p>n. pizze n. pizzas Ø 34 cm</p>	<p>400 Volt AC 3/N/PE 230 Volt AC 1/N/PE 7,2 kW</p> <p>Misure interne camera LxPxH Chamber internal dimensions LxDxH 700 x 1050 x 145 mm</p> <p>Versione TOP / TOP version LxPxH 670 x 1035 x 145 mm</p>	<p>60 - 450 °C</p> <p>97 kg TOP 122 kg</p> <p>€ 1.873,00</p> <p>versione TOP TOP version € 2.332,00</p>
<p><b>SB6G - SB6G TOP</b></p> <p>Dim. con manico e cavo Dim. with handle and cable 1350 x 1100 x 430 mm</p>	<p>n. pizze n. pizzas Ø 34 cm</p>	<p>400 Volt AC 3/N/PE 230 Volt AC 1/N/PE 8,8 kW</p> <p>Misure interne camera LxPxH Chamber internal dimensions LxDxH 1050 x 700 x 145 mm</p> <p>Versione TOP / TOP version LxPxH 1020 x 685 x 145 mm</p>	<p>60 - 450 °C</p> <p>115 kg TOP 139 kg</p> <p>€ 2.028,00</p> <p>versione TOP TOP version € 2.501,00</p>
<p><b>SBD44 - SBD44 TOP</b></p> <p>Dim. con manico e cavo Dim. with handle and cable 900 x 880 x 760 mm</p>	<p>n. pizze n. pizzas Ø 30 cm</p>	<p>400 Volt AC 3/N/PE 230 Volt AC 1/N/PE 8,8 kW</p> <p>Misure interne camera LxPxH Chamber internal dimensions LxDxH 620 x 620 x 145 mm</p> <p>Versione TOP / TOP version LxPxH 600 x 605 x 145 mm</p>	<p>60 - 450 °C</p> <p>134 kg TOP 160 kg</p> <p>€ 2.440,00</p> <p>versione TOP TOP version € 3.166,00</p>
<p><b>SB44 - SB44 TOP</b></p> <p>Dim. con manico e cavo Dim. with handle and cable 1000 x 1100 x 760 mm</p>	<p>n. pizze n. pizzas Ø 34 cm</p>	<p>400 Volt AC 3/N/PE 230 Volt AC 1/N/PE 9,6 kW</p> <p>Misure interne camera LxPxH Chamber internal dimensions LxDxH 700 x 700 x 145 mm</p> <p>Versione TOP / TOP version LxPxH 670 x 685 x 145 mm</p>	<p>60 - 450 °C</p> <p>160 kg TOP 186 kg</p> <p>€ 2.531,00</p> <p>versione TOP TOP version € 3.257,00</p>

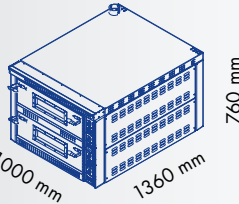
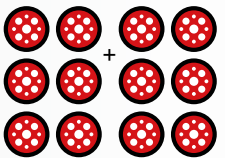
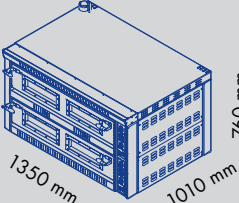
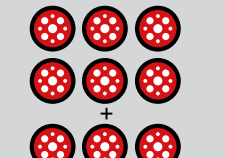
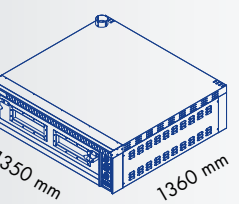
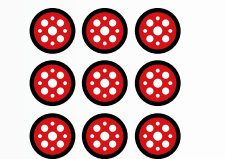
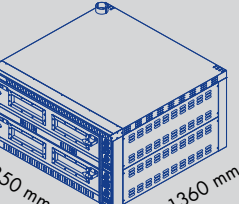
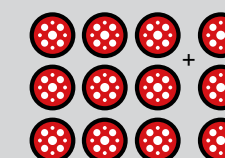
<p><b>SB66 - SB66 TOP</b></p>  <p>1000 mm 1360 mm 760 mm</p> <p>Dim. con manico e cavo Dim. with handle and cable 1000 x 1450 x 760 mm</p>	●	<p>n. pizze n. pizzas Ø 34 cm</p> 	<p>⚡ 400 Volt AC 3/N/PE 230 Volt AC 1/N/PE 14,4 kW</p> <p>Misure interne camera LxPxH Chamber internal dimensions LxDxH 700 x 1050 x 145 mm</p> <p>⌚ 60 - 450 °C</p> <p>⚖️ 196 kg TOP 294 kg</p>	<p>€ 3.118,00</p>	<p>versione TOP TOP version € 4.036,00</p>
<p><b>SB66G - SB66G TOP</b></p>  <p>1350 mm 1010 mm 760 mm</p> <p>Dim. con manico e cavo Dim. with handle and cable 1350 x 1100 x 430 mm</p>	●	<p>n. pizze n. pizzas Ø 34 cm</p> 	<p>⚡ 400 Volt AC 3/N/PE 230 Volt AC 1/N/PE 17,6 kW</p> <p>Misure interne camera LxPxH Chamber internal dimensions LxDxH 1050 x 700 x 145 mm</p> <p>⌚ 60 - 450 °C</p> <p>⚖️ 210 kg TOP 256 kg</p>	<p>€ 3.363,00</p>	<p>versione TOP TOP version € 4.309,00</p>
<p><b>SB9 - SB9 TOP</b></p>  <p>1350 mm 1360 mm 430 mm</p> <p>Dim. con manico e cavo Dim. with handle and cable 1350 x 1450 x 430 mm</p>	●	<p>n. pizze n. pizzas Ø 34 cm</p> 	<p>⚡ 400 Volt AC 3/N/PE 230 Volt AC 1/N/PE 13,2 kW</p> <p>Misure interne camera LxPxH Chamber internal dimensions LxDxH 1050 x 1050 x 145 mm</p> <p>⌚ 60 - 450 °C</p> <p>⚖️ 121 kg TOP 156 kg</p>	<p>€ 2.753,00</p>	<p>versione TOP TOP version € 3.360,00</p>
<p><b>SB99 - SB99 TOP</b></p>  <p>1350 mm 1360 mm 760 mm</p> <p>Dim. con manico e cavo Dim. with handle and cable 1350 x 1450 x 760 mm</p>	●	<p>n. pizze n. pizzas Ø 34 cm</p> 	<p>⚡ 400 Volt AC 3/N/PE 26,4 kW</p> <p>⌚ 60 - 450 °C</p> <p>⚖️ 309 kg TOP 375 kg</p> <p>Misure interne camera LxPxH Chamber internal dimensions LxDxH 1050 x 1050 x 145 mm</p> <p>Versione TOP / TOP version LxPxH 1020 x 1035 x 145 mm</p>	<p>€ 4.808,00</p>	<p>versione TOP TOP version € 6.022,00</p>



# FOX

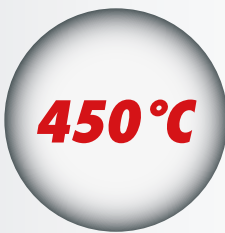

L'ultimo forno pizza nato in casa Gam si rivolge a chi vuole un forno che sia **funzionale ma soprattutto economico**. Fox ha comandi analogici, facciata in acciaio inox, camera in lamiera alluminata e piano di cottura in materiale refrattario. Raggiunge i 450 °C. Fox è il forno ideale per il pizzaiolo alle prime armi che abbia a cuore il **risparmio economico senza compromettere gli standard di lavoro**.

*The last pizza oven made by Gam International suits the baker who is looking for **an Italian oven both functional and cheap**. Fox is analogic, the front is made of stainless steel and the baking chamber of aluminium coated iron, it has refractory stone at the bottom. It's Reaches up to 450 °C / 842 °F. Fox is the ideal oven for the pizza baker who has at heart the **money saving without compromising the work results**.*

**ATTENZIONE: 2 anni di garanzia su tutti i modelli (esclusa la centralina elettronica)**  
**WARNING: 2 years of warranty on all models (electronic board not included)**

## Forno per pizza funzionale ed economico *Pizza oven functional and cheap*

### CARATTERISTICHE PRINCIPALI

- Elettromeccanico
- Camera di cottura in lamiera alluminata
- Monoblocco
- Piatea in pietra refrattaria

### MAIN FEATURES

- Analogic
- Baking chamber of aluminium coated iron
- Single block
- Refractory stone at the bottom

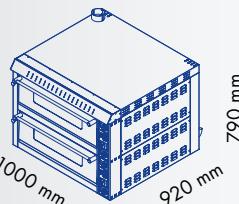
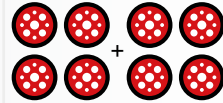
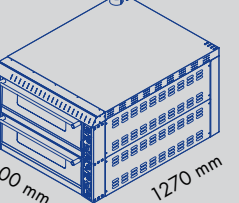
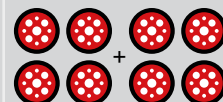
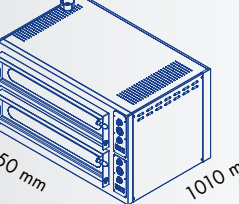
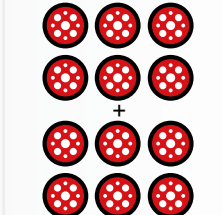

<p><b>FOX 44</b></p>  <p>Dim. con manico e cavo Dim. with handle and cable 1000 x 1140 x 790 mm</p>	<p>n. pizze n. pizzas Ø 34 cm</p> <p>● </p>	<p>⚡ 400 Volt AC 3/N/PE 230 Volt AC 1/N/PE 9,6 kW</p> <p>Misure interne / Internal dimensions LxPxH 700 x 700 x 145 mm</p>	<p>🌡️ 60 - 450 °C</p> <p>🔒 142 kg</p>	<p>€ 1.727,00</p>
<p><b>FOX 66</b></p>  <p>Dim. con manico e cavo Dim. with handle and cable 1000 x 1490 x 790 mm</p>	<p>n. pizze n. pizzas Ø 34 cm</p> <p>● </p>	<p>⚡ 400 Volt AC 3/N/PE 230 Volt AC 1/N/PE 14,4 kW</p> <p>Misure interne / Internal dimensions LxPxH 700 x 1050 x 145 mm</p>	<p>🌡️ 60 - 450 °C</p> <p>🔒 193 kg</p>	<p>€ 2.213,00</p>
<p><b>FOX 66G</b></p>  <p>Dim. con manico e cavo Dim. with handle and cable 1350 x 1140 x 790 mm</p>	<p>n. pizze n. pizzas Ø 34 cm</p> <p>● </p>	<p>⚡ 400 Volt AC 3/N/PE 230 Volt AC 1/N/PE 17,6 kW</p> <p>Misure interne / Internal dimensions LxPxH 1050 x 700 x 145 mm</p>	<p>🌡️ 60 - 450 °C</p> <p>🔒 210 kg</p>	<p>€ 2.398,00</p>



# FENNEC



**450°C**

**1 pizza  
oppure  
1 teglia**

**1 pizza  
or  
1 tray**

L'ultimo forno pizza nato in casa Gam si rivolge a chi vuole un forno che sia funzionale ma soprattutto economico.

Fennec ha comandi analogici, facciata in acciaio inox, camera in lamiera alluminata e piano di cottura in materiale refrattario o a richiesta in acciaio inox.  
**Raggiunge i 450 °C.**

Fennec è il forno ideale per il pizzaiolo alle prime armi che abbia a cuore il risparmio economico senza compromettere gli standard di lavoro.

The last pizza oven made by Gam International *suits the baker who is looking for an Italian oven both functional and cheap.*

Fennec is analogic, the front is made of stainless steel and the baking chamber of aluminium coated iron, it has refractory stone or on demand Stainless Steel at the bottom.

**It's reaches up to 450 °C / 842 °F.**

Fennec is *the ideal oven for the pizza baker who has at heart the money saving without compromising the work results.*

**ATTENZIONE: 2 anni di garanzia su tutti i modelli (esclusa la centralina elettronica)**  
**WARNING: 2 years of warranty on all models (electronic board not included)**

## Forno per pizza funzionale ed economico *Pizza oven functional and cheap*







### CARATTERISTICHE PRINCIPALI

- Elettromeccanico
- Camera di cottura in lamiera alluminata
- Monoblocco
- Platea in pietra refrattaria oppure in acciaio inox a richiesta

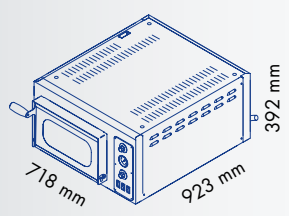
### MAIN FEATURES

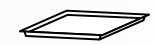
- Analogic
- Baking chamber of aluminium coated iron
- Single block
- Refractory stone or on demand Stainless Steel at the bottom



<p><b>FENNEC</b></p>  <p>718 mm 923 mm 392 mm</p> <p>Dim. con manico e cavo Dim. with handle and cable 718 x 1003 x 392 mm</p>		<p>n. 1 teglia n. 1 tray 60x40 cm</p> 	<p> 400 Volt AC 3/N/PE 230 Volt AC 1/N/PE 3,15 kW</p> <p>Misure interne camera LxPxH Chamber internal dimensions LxDxH 42 x 615 x 250 mm</p>	<p> 60 - 450 °C</p> <p> 47 kg</p>	<p>€ .....<b>00</b></p>
---	---	---	---	---	-------------------------

**PAGINA VUOTA**

### NO GLUTINE

La nostra azienda, grazie alle preziose indicazioni che provengono da chi si affida da anni al nostro marchio, è sempre più attenta alle esigenze della nostra clientela, tramite anche la ricerca di nuovi materiali e soluzioni tecniche.

Per quei locali che pur con poco spazio a disposizione vogliono dare un servizio completo alla propria clientela, GAM ha realizzato una linea "no glutine" con un tavolo di preparazione in acciaio inox e dei fornetti professionali di piccole dimensioni ma molto performanti.

#### Linee guide per una PIZZERIA:

**In deposito:** stoccare materie prime senza glutine su scaffali, armadi e/o pensili dedicati ed identificati.

**Condimenti:** per evitare contaminazioni con le farine tradizionali, gli ingredienti utilizzati per il condimento della pizza senza glutine devono essere di uso esclusivo e l'area adibita alla preparazione della pizza deve essere protetta. Non prelevare gli ingredienti dal banco produzione/condimento della pizza tradizionale. Per ridurre ulteriormente i pericoli di contaminazione, si suggerisce l'utilizzo di farina senza glutine per lo spolvero per tutte le pizze, anche quelle tradizionali.

**Tavolo di preparazione:** non è possibile utilizzare lo stesso tavolo di preparazione usato per la pizza tradizionale. GAM ha realizzato allo scopo un tavolo **pizza trasportabile**, totalmente in acciaio INOX 304, idoneo all'uso alimentare, dalle dimensioni di mm 1000 x mm 700 ed un ripiano dalle dimensioni di mm 1000 x 226 mm, sollevato di mm 341 dal piano di lavoro che permette l'appoggio delle vaschette condimento.

**Forno:** consigliamo un forno dedicato esclusivamente alla cottura delle pizze senza glutine. I forni di nostra produzione **MD1, MD11, Dolomiti B1, B11 e B1E**, si adattano perfettamente alla cottura "no glutine". Le ridotte dimensioni di ingombro (mm 585x540) permettono, pur con poco spazio a disposizione, di realizzare un' apposita area per la preparazione e la cottura delle pizze "no glutine".

### GLUTEN FREE

*Our company, thanks to the precious indications that come from those who have relied for years on our brand, is increasingly attentive to the needs of our customers, through the search for new materials and technical solutions.*

*For even those companies where space is at a premium but which still want to give full service to their customers, GAM has created a „gluten free“ line with a preparation table in stainless steel and professional ovens of small size but very high performance.*

#### Guidelines for a PIZZERIA:

**In storage:** to store gluten-free raw materials on shelves, cabinets and/or wall units that are dedicated and identified.

**Dressings:** to avoid contamination with traditional flours, the ingredients used for the gluten-free pizza dressing must be of exclusive use and the area used for the preparation of the pizza must be protected. Do not take the ingredients from the production/conditioning counter of traditional pizza. To further reduce the risk of contamination, the use of gluten-free flour for sprinkling is recommended for all pizzas, including traditional ones.

**Preparation table:** it is not possible to use the same preparation table used for traditional pizza. GAM has created for this purpose a transportable pizza table, made entirely of AISI 304 stainless steel, suitable for food use, with dimensions of 1000 x 700 mm and a shelf with dimensions of 1000 x 226 mm, lifted off the worktop by 341 mm and designed to support the dressing trays.

**Oven:** we recommend an oven dedicated exclusively to cooking gluten-free pizzas. Our **MD1, MD11, Dolomiti, B1, B11 and B1E** ovens are perfectly suited to „gluten-free“ cooking. The reduced dimensions (585x540 mm) permit creating a special area for the preparation and cooking of „gluten-free“ pizzas even where space is at a premium.

**FOTO**

- MODELLO CONSIGLIATO PER IL "NO GLUTINE"
- RECOMMENDED MODEL FOR "GLUTEN FREE"

**SUN**

**FOTO**

**450° C**

**1 pizza  
oppure  
1 teglia**

**1 pizza  
or  
1 tray**

Il forno XXXXXX è un **piccolo forno meccanico altamente performante che è economico, facile da usare, a risparmio energetico e sicuro**. Il forno è completamente fatto di acciaio inossidabile ed è **perfettamente isolato, è sicuro, facile da usare e da pulire**. Dotato di porta in vetro e luce interna è ideale per coloro a cui occorre monitorare con attenzione la cottura del cibo all'interno. XXXXXX è dotato di una apertura interna di 12 cm di altezza che lo rende **ideale per tutti coloro i quali hanno necessità di cuocere o riscaldare velocemente qualunque tipo di cibo senza occupare troppo spazio o assorbire troppa corrente**. XXXXXX è uno strumento prezioso e versatile in qualunque cucina.

The oven XXXXXX is a **small mechanical oven with high performance, cheap, easy to use, energy saving and safe**. The oven is completely made of stainless steel and is **fully insulated, it is safe, easy to use and clean**. Equipped with glass door and interior light, it is perfect for those who need to carefully check the cooking of the food inside. XXXXXX has an inner opening of 12 cm in height, making it **perfect for all those who need to cook or reheat quickly any type of food without taking up too much space or absorb too much energy**. XXXXXX is a valuable and versatile equipment in any kitchen.

**ATTENZIONE: 2 anni di garanzia su tutti i modelli (esclusa la centralina elettronica)**  
**WARNING: 2 years of warranty on all models (electronic board not included)**

## Un piccolo forno funzionale ed economico A little oven functional and cheap

### CARATTERISTICHE PRINCIPALI

- Elevata altezza interna
- Meccanico
- Porta a doppio vetro per evitare scottature e monitorare il cibo in cottura
- Luce interna
- Totalmente in acciaio inossidabile
- Solo 2.3 kW → Consumo ridotto
- Raggiunge 450° C → Versatile
- Raggiunge 350° C in meno di 20 minuti → Veloce
- Doppio termostato con cielo e platea indipendenti → Accurato
- Porta rimovibile per facilitare la pulizia
- Isolamento a fibra di vetro
- Pietra refrattaria rettificata

### MAIN FEATURES

- Higher baking chamber
- Mechanical
- Double glass door to check the baking and avoid any burns
- Interior light
- Completely in stainless steel
- Solo 2.3 kW → Low power consumption
- Raggiunge 450° C → Versatile
- Raggiunge 350° C in less than 20 minutes → Fast
- Double thermostat with top and bottom independent → Accurate
- Removable door to ease cleaning
- Glass fiber insulation
- No gap refractory stone

<p><b>XXXXXXXXXX</b></p>	<p>n. pizze n. pizzas Ø 35 cm</p> <p>oppure n. teglie or n. trays 35x40 cm</p>	<p>230 Volt AC 1/N/PE <b>2.3 kW</b></p> <p>Misure interne camera LxPxH Chamber internal dimensions LxDxH 360 x 410 x 125 mm</p>	<p>50 - 450° C</p> <p>32 kg</p>	<p>€ .....00</p>

**VERIFICARE DIMENSIONI E POTENZE  
SU PROTOTIPO DEFINITIVO**



- MODELLO CONSIGLIATO PER IL "NO GLUTINE"
- RECOMMENDED MODEL FOR "GLUTEN FREE"

# DOLOMITI



**350°C**

**1 pizza  
oppure  
1 teglia**

**1 pizza  
or  
1 tray**

Il forno Dolomiti è un **piccolo forno meccanico altamente performante che è economico, facile da usare, a risparmio energetico e sicuro**. Il forno è completamente fatto di acciaio inossidabile ed è **perfettamente isolato, è sicuro, facile da usare e da pulire**. Dotato di porta in vetro e luce interna è ideale per coloro a cui occorre monitorare con attenzione la cottura del cibo all'interno. Dolomiti è dotato di una apertura interna di 12 cm di altezza che lo rende **ideale per tutti coloro i quali hanno necessità di cuocere o riscaldare velocemente qualunque tipo di cibo senza occupare troppo spazio o assorbire troppa corrente**. Dolomiti è uno strumento prezioso e versatile in qualunque cucina.

*The oven Dolomiti is a **small mechanical oven with high performance, cheap, easy to use, energy saving and safe**. The oven is completely made of stainless steel and is **fully insulated, it is safe, easy to use and clean**. Equipped with glass door and interior light, it is perfect for those who need to carefully check the cooking of the food inside. Dolomiti has an inner opening of 12 cm in height, making it **perfect for all those who need to cook or reheat quickly any type of food without taking up too much space or absorb too much energy**. Dolomiti is a valuable and versatile equipment in any kitchen.*

**ATTENZIONE: 2 anni di garanzia su tutti i modelli (esclusa la centralina elettronica)**  
**WARNING: 2 years of warranty on all models (electronic board not included)**



## Un piccolo forno funzionale ed economico *A little oven functional and cheap*

### CARATTERISTICHE PRINCIPALI

- Elevata altezza interna
- Meccanico
- Porta a doppio vetro per evitare scottature e monitorare il cibo in cottura
- Luce interna
- Totalmente in acciaio inossidabile
- Solo 1.6 kw ➔ Consumo ridotto
- Raggiunge 350°C ➔ Versatile
- Raggiunge 300°C in meno di 20 minuti ➔ Veloce
- Doppio termostato con cielo e platea indipendenti ➔ Accurato
- Porta rimovibile per facilitare la pulizia
- Isolamento a fibra di vetro
- Pietra refrattaria rettificata

### MAIN FEATURES

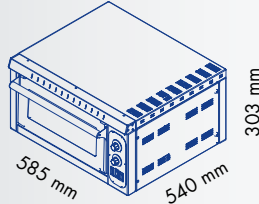
- Higher baking chamber
- Mechanical
- Double glass door to check the baking and avoid any burns
- Interior light
- Completely in stainless steel
- Only 1.6 kw ➔ Low power consumption
- It reaches 350 ° C ➔ Versatile
- It reaches 300 ° C in less than 20 minutes ➔ Fast
- Double thermostat with top and bottom independent ➔ Accurate
- Removable door to ease cleaning
- Glass fiber insulation
- No gap refractory stone

<p><b>DOLOMITI</b></p>  <p>585 mm 540 mm 303 mm</p> <p>Dim. con manico e cavo Dim. with handle and cable 585 x 580 x 303 mm</p>	<p>n. pizze n. pizzas Ø 35 cm</p>	<p>⚡ 230 Volt AC 1/N/PE 2,0 kW</p>	<p>🕒 50 - 350 °C</p>	<p>€ 812,00</p>
	<p>● oppure n. teglie or n. trays 35x40 cm</p> 	<p>Misure interne camera LxPxH Chamber internal dimensions LxDxH 360 x 410 x 125 mm</p>	<p>🔒 32 kg</p>	



- MODELLO CONSIGLIATO PER IL "NO GLUTINE"
- RECOMMENDED MODEL FOR "GLUTEN FREE"

# MD1 - MD1+1

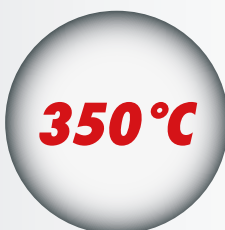

I forni MD1 e MD1+1 sono forni elettromeccanici di **piccole dimensioni, altamente performanti e dall'ottimo rapporto qualità/prezzo**. Questi forni sono realizzati completamente in acciaio inossidabile e sono **perfettamente isolati, sicuri, facile da usare e da pulire**. Dotati di porta in vetro e luce interna sono l'ideale per coloro a cui occorre monitorare con attenzione la cottura del cibo all'interno.

**MD1 è ideale per bar, pub, ristoranti e piccole pizzerie** che hanno necessità di cuocere una pizza in pochi minuti, ma anche per pizzerie che sono già dotate di forno ma che devono essere attrezzate per servire saltuari **clienti celiaci**.

**ATTENZIONE: 2 anni di garanzia su tutti i modelli (esclusa la centralina elettronica)**  
**WARNING: 2 years of warranty on all models (electronic board not included)**

*The ovens MD1 and MD1+1 are **small electromechanical ovens with high performance and great quality / price value**. The ovens are completely made of stainless steel and are **fully insulated, safe, easy to use and to clean**. Equipped with glass door and interior light, they are perfect for those who need to carefully check the cooking of the food inside the chamber.*

**MD1 is perfect for cafés, pubs, restaurants and small pizzerias** where the pizza should be baked in a few minutes, but also for pizzerias that are already equipped with oven but have to be equipped in order to serve occasional **celiac customers**.

# Un piccolo forno funzionale ed economico A little oven functional and cheap





## CARATTERISTICHE PRINCIPALI

- Elettromeccanico
- Porta a doppio vetro per evitare scottature e monitorare il cibo in cottura
- Luce interna
- La struttura esterna, (fianchi, tetto e schiena) e la camera di cottura sono in acciaio inox
- Solo 1.6 kw ➔ Consumo ridotto
- Raggiunge 350°C ➔ Versatile
- Raggiunge 300°C in meno di 20 minuti ➔ Veloce
- Doppio termostato con cielo e platea indipendenti ➔ Accurato
- Porta rimovibile per facilitare la pulizia
- Isolamento a fibra di vetro
- Pietra refrattaria rettificata
- Disponibile singolo o doppia camera

## MAIN FEATURES

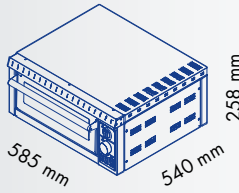
- Electromechanical
- Double glass door to check the baking and avoid any burns.
- Inner light
- Completely in stainless steel
- Only 1.6 kw ➔ Low power consumption
- It reaches 350°C ➔ Versatile
- It reaches 300°C in less than 20 minutes ➔ Fast
- Double thermostat with top and bottom independent ➔ Accurate
- Removable door to ease cleaning
- Glass fiber insulation
- No gap refractory stone
- Available with one or double chamber

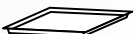
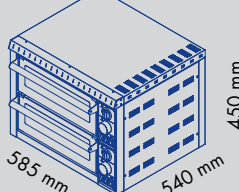

<p><b>MD 1</b></p>  <p>585 mm 540 mm 258 mm</p> <p>Dim. con manico e cavo Dim. with handle and cable 585 x 580 x 258 mm</p>	●	<p>n. pizze n. pizzas Ø 35 cm</p>  <p>oppure n. teglie or n. trays 35x40 cm</p> 	<p>⚡</p> <p>230 Volt AC 1/N/PE 1,6 kW</p> <p>Misure interne camera LxPxH Chamber internal dimensions LxDxH 360 x 410 x 80 mm</p>	<p>🌡️</p> <p>50 - 350 °C</p> <p>⚖️</p> <p>29 kg</p>	<p>€ 759,00</p>
<p><b>MD 1+1</b></p>  <p>585 mm 540 mm 450 mm</p> <p>Dim. con manico e cavo Dim. with handle and cable 585 x 580 x 450 mm</p>	●	<p>n. pizze n. pizzas Ø 35 cm</p>  <p>oppure n. teglie or n. trays 35x40 cm</p> 	<p>⚡</p> <p>230 Volt AC 1/N/PE 3,2 kW</p> <p>Misure interne camera LxPxH Chamber internal dimensions LxDxH 360 x 410 x 80 mm</p>	<p>🌡️</p> <p>50 - 350 °C</p> <p>⚖️</p> <p>51 kg</p>	<p>€ 1.369,00</p>



- MODELLO CONSIGLIATO PER IL "NO GLUTINE"
- RECOMMENDED MODEL FOR "GLUTEN FREE"

**B**



B1



B1 electronic

**350°C**

pizze  
**1-2**  
pizzas

Il forno B1 è un **piccolo forno altamente performante che è economico, facile da usare, a risparmio energetico e sicuro.**

Il forno è completamente fatto di acciaio inossidabile ed è **perfettamente isolato, è sicuro, facile da usare e da pulire.**

The oven B1 is a **small electromechanical oven with high performance and great quality / price value.**

The ovens are completely made of stainless steel and are **fully insulated, safe, easy to use and to clean.**

**ATTENZIONE: 2 anni di garanzia su tutti i modelli (esclusa la centralina elettronica)**  
**WARNING: 2 years of warranty on all models (electronic board not included)**

## Un piccolo forno meccanico ed economico A little mechanical and cheap oven

### CARATTERISTICHE PRINCIPALI

- Meccanico
- Camera in acciaio inossidabile
- Solo 1.6 kw ➔ Consumo ridotto
- Raggiunge 350°C ➔ Versatile
- Raggiunge 300°C in meno di 20 minuti ➔ Veloce
- Isolamento a fibra di vetro
- Pietra refrattaria rettificata
- Disponibile singolo o doppia camera
- Disponibile nel modello elettronico
- Porta in acciaio inox

### MAIN FEATURES

- Mechanical
- Chamber in stainless steel
- Only 1.6 kw ➔ Low power consumption
- It reaches 350°C ➔ Versatile
- It reaches 300°C in less than 20 minutes ➔ Fast
- Glass fiber insulation
- No gap refractory stone
- Available with one or double chamber
- Available in the electronic version too
- Stainless steel door

